

SURFACE FINISHING WITH 81 FS 00 CARTRIDGES

The cartridge 81 FS 00 R-12 is intended to perform finishing operations when used in conjunction with other cartridges as shown in diagrams opposite. They have a fine adjusting set screw to enable the cartridge to be pulled back and pushed forward again to the initial preset position.

Stock removal for finishing should be no more than 1 mm and preferably 0,5 mm; the finishing insert actually removing a maximum 0,03 mm due to it trailing the main cutting inserts.

On the cutter series 8000 V one, two or even three of the roughing cartridges may be replaced by an 81 FS 00 R-12 cartridge. On the cutters 8100 V, the finishing cartridge is mounted in one Ø 125 and 160 mm or two Ø 200 to 400 mm additional and independent pockets.

For producing a super finish, one, two or even three (according to diameter), of the roughing cartridges is replaced by an 81 FS 00 R-12 finishing cartridge.

These cartridges, having a fine adjusting set screw, are set according to the dimension (axial shift) "X".

X = 0,03 - 0,05 mm

(X = 0,02 mm with an as pressed insert with a nose radius).

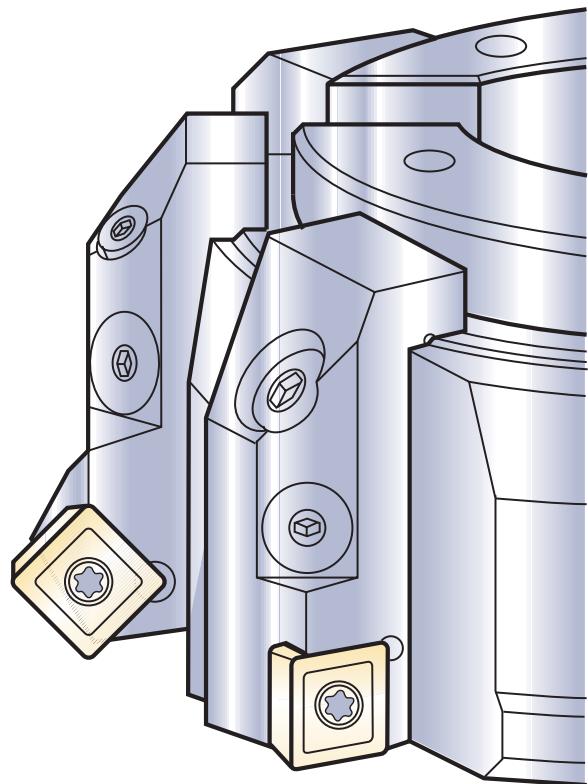

8000, 8100 VH 45

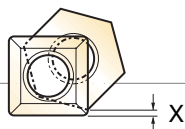

8000, 8100 VT/VTE 60

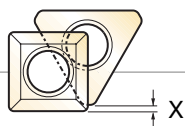

8000, 8100 VS/VSE 45

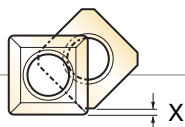

8000, 8100 VR 00

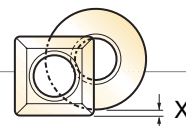

8000, 8100 VSE 75

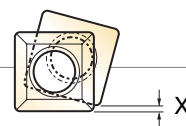

8000, 8100 VOD 45

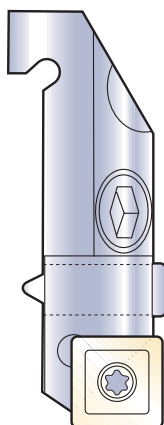
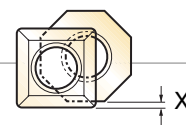

Spares						
Finishing Insert Part Number	Finishing Cartridge	Cartridge Fixing Screw	Adjusting Cartridge Screw	Blank Cartridge	Fixing Insert Screw	Screw Driver
SPHX 12 M5 12-EN	81 FS 00 R-12	7065	72.602	70.951	D5013T	T20

MOUNTING / ADJUSTMENTS

MOUNTING / ADJUSTING CARTRIDGES

For the majority of current applications, 8000 V and 8100 V cutters with interchangeable cartridges do not have to be adjusted. The cartridges therefore are mounted by pressing the calibrated heel up against the setting track on the tool body (runout 0,05 mm max., with inserts with ground wiper edges). However, if greater accuracy is required, they may be adjusted individually with a runout of 2- μ m.

A MOUNTING OF CARTRIDGES WITHOUT ADJUSTMENT

1. Lubricate the screw under the head and on the thread (preferably with HSC paste).
2. Clean cartridges and their pockets located in the milling cutter.
3. Introduce the first cartridge into its pocket and check if it moves freely.
4. Introduce screw No. 1 and tighten it moderately whilst pushing the cartridge against its axial setting track; mount all the cartridges in the same way.
5. Introduce screw No. 2 and lock it (tightening torque 10 Nm).
6. Lock screw No. 1 well with an extended allen key (tightening torque 18 Nm).
7. Mount the indexable inserts.

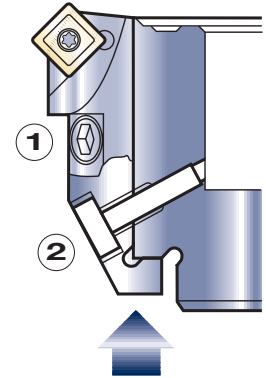

MOUNTING / ADJUSTMENTS

MOUNTING / ADJUSTING CARTRIDGES

B MOUNTING OF CARTRIDGES WITH ADJUSTMENT

For adjusting 8000 V cutters with interchangeable cartridges the same setting device is used for 8100 V cutters.

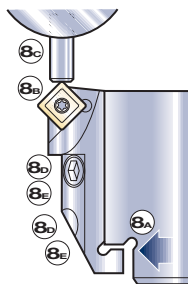
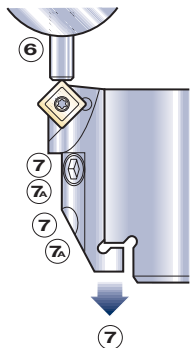
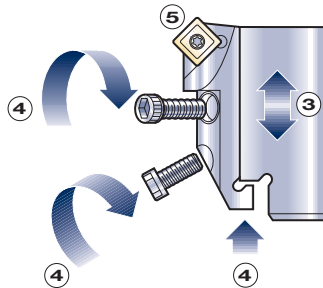

Complete setting unit for 8000 V and 8100 V cutters is part No. 70850:

1. Lubricate the screws under the head and on the thread (preferably with HSC paste).
2. Clean the cartridges and their pockets located in the milling cutter.
3. Introduce the first cartridge into its pocket and check it moves freely.
4. Introduce screws No. 1 and No. 2 whilst pushing the cartridge against its axial setting track, tighten screw No. 1.
5. Mount an insert with ground periphery which will serve as a gauge.
6. Place the adjustment device onto the checking track of the milling cutter (which should have been lubricated slightly beforehand). Gauge the height of the first mounted cartridge, then set the dial to zero (maximum half a revolution of the clock, so as to avoid the plunger hitting the inserts later on when checking the final axial runout). Lock the dial gauge. Turn the dial so that it indicates +0,02 mm.
7. Slightly loosen both screws; reverse the cartridge to just below zero in relation to pre-set +0,02 mm and again moderately tighten screw No. 1. Using screw No. 2 advance the cartridge to zero. Then loosen screw No. 2.

INSTRUCTIONS FOR TIGHTENING

After height zero has been reached:

- A Lock screw No. 1 securely with the extended allen key No. 70.901 (tightening torque 14 Nm). When doing this it is possible that the cartridge may reverse a little.
 - B Re-tighten screw No. 2 to jack cartridge back to zero position.
8. To adjust the other cartridges, proceed as follows:
 - A Mount the cartridge using screw No. 1 which must be moderately tightened.
 - B Mark, as a reference face with a red felt-tipped pen, the insert from the preceding cartridge and introduce it so as to use the same wiper edge.
 - C Rotate the dial gauge above the insert which has been mounted on the new cartridge.
 - D Introduce screw No. 2 which will help push the cartridge up to position zero on the dial. Loosen the screw.
 - E From this point onwards, follow the tightening instructions described in B 7 A and B.
 9. Once the mounting of the cartridges is complete, mount the indexable inserts.

NOTE: By proceeding in this way with the mounting of cartridges, the insert seats should all be at a precise height ($\pm 0,002$ mm); only variations in the insert dimensions will then influence the axial runout of the milling cutter.

MOUNTING / ADJUSTING CARTRIDGES

C MOUNTING & SETTING OF THE FINISHING CARTRIDGES

81 FS 00 R-12

The 8100 V series milling cutters have one (diameter 125 to 160 mm) or two (diameter 200 to 400 mm) additional and independent pockets inserted between the roughing cartridge pockets and stamped with an "F". They have a conical indentation designed for use with a set screw, which provides micro adjustment for the 81 FS 00 R-12 finishing cartridge when in use.

IMPORTANT!

If the finishing cartridges are not used, the pocket must be protected by a blank cartridge 70.951.

The 8000V series of milling cutters have no additional and independent pockets but, according to their diameter, one, two or even three roughing cartridges can be replaced by one finishing cartridge 81 FS 00 R-12.

NOTE: When using two or even three finishing cartridges, their equal spacing on the milling cutter circumference must be ensured and the axial runout between the edges of the wiper inserts must be as small as possible.

MOUNTING & SETTING INSTRUCTIONS

- A** After the 81 FS 00 R-12 cartridge and its pocket in the cutter body have been cleaned, place the cartridge into its pocket and locate the heel against the setting track.
B Introduce the cartridge fixing screw and lightly tighten. The finishing inserts will protrude from the cutting plane of the roughing cartridges 0,2 to 1 mm depending upon the roughing inserts being used.
- Place the adjustment device onto the setting track of the cutter body check each insert on the roughing cartridges, whose mounting is described in **A** and **B** so that the highest insert can be marked and used to set the dial gauge to zero.
- A** Rotate the dial gauge until the plunger is placed above the centre of the finishing insert cutting edge.
B Screw in the set screw, which will move the 81 FS 00 R-12 finishing cartridge off the setting track until the dial hand indicates +0,03 to 0,05 mm from the zero already set. If the roughing cartridges are equipped with SCMT utility inserts (with as pressed periphery), the offset should only be +0,02 mm.
C Loosen the cartridge fixing screw and move the cartridge up and down to verify the dimension already set. If necessary, correct the preset dimension by adjusting the set screw.
- Lightly tighten the cartridge fixing screw.
- The 81 FS 00 R-12 finishing cartridges are able to be pulled back or pushed forward as necessary to allow for roughing or finishing work as they will always return to the dimension as preset in 3 B and C. So, simply unscrew the fixing screw, push the finishing cartridge either forward or backwards, then lock the screw again.

Note: Not suitable for use on 8010 V cutter bodies.

